

MIXING VALVES & ACTUATORS



LK840 Three-way Mixing Valve

Mixing valves with a rotating inner segment intended for heating or solar thermal systems with water or antifreeze fluid.

They have a linear flow rate characteristic in the range between 30° and 60° of the segment rotation.

The valves can be fitted with any actuator supplied by Regulus.

These valves can be easily converted between a left or right hand version for use in different positions in a heating system.

Technical Data

MAX. WORKING PRESSURE	10 bar
FLUID WORKING TEMPERATURE	5 to 110 °C
MATERIALS	
VALVE BODY	brass
VALVE SPINDLE	brass
ROTATING SEGMENT	brass

Flow rate characteristic

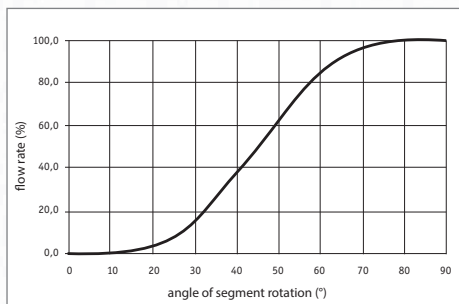

Pressure drop

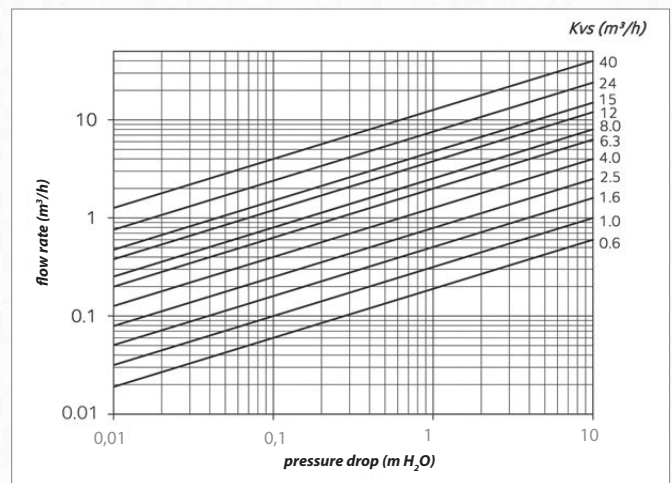

Dimensions and Models

LK840 with copper connection

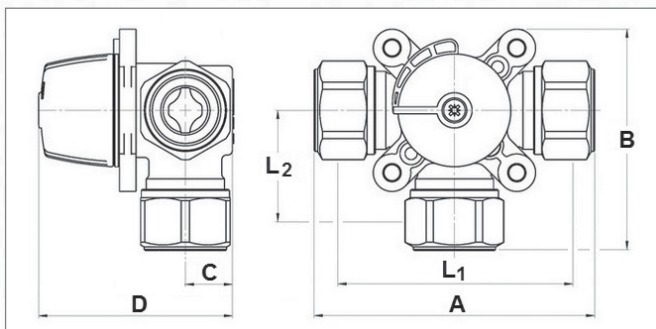

CONNECTION	mm	15	18	22	22	28	28
A	mm	114	114	114	87	120	120
B	mm	92	92	92	78	95	95
C	mm	20	20	20	20	20	20
D	mm	82	82	82	82	82	82
L ₁	mm	80	80	80	72	80	82
L ₂	mm	38	38	38	35	41	41
WEIGHT	kg	0.8	0.8	0.8	0.8	0.8	0.8
Kvs	m³/h	2.5	2.5	2.5	6.3	4.0	6.3
CODE	--	15771	15772	15773	15774	15775	15776

Dimensions and Models

LK840 with inner thread

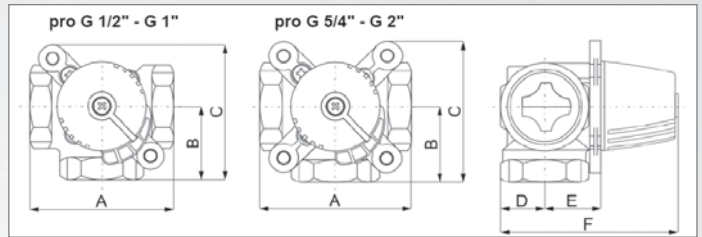
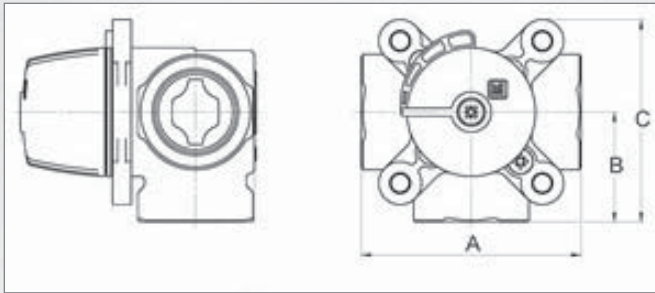

Dimensions of the new generation valves 2.0 (codes 16xxx).

CONNECTION	--	1/2" F	1/2" F	3/4" F	3/4" F	1" F	1" F	5/4" F	6/4" F	2" F
A	mm	80	80	70	70	70	70	84	106	106
B	mm	40	40	35	35	35	35	42	53	53
C	mm	75	75	63	63	63	63	77	88	88
WEIGHT	kg	0.7	0.7	0.5	0.5	0.5	0.5	0.8	1.4	1.6
MAX. PRESSURE DIFFERENCE IN EITHER DIRECTION	m H ₂ O	5	5	5	5	5	5	5	5	5
Kvs	m³/h	1.6	2.5	4.0	6.3	6.3	10.0	16.0	25.0	40.0
CODE	--	13998	11489	16760	16698	16758	16700	16693	16762	16697

LK840 with outer thread

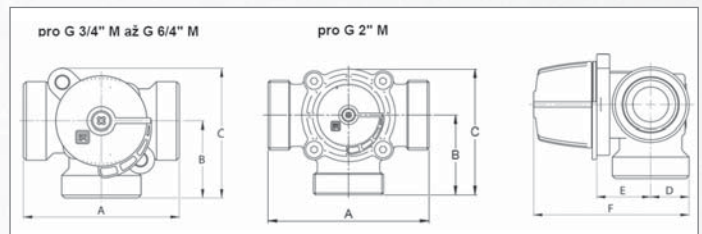
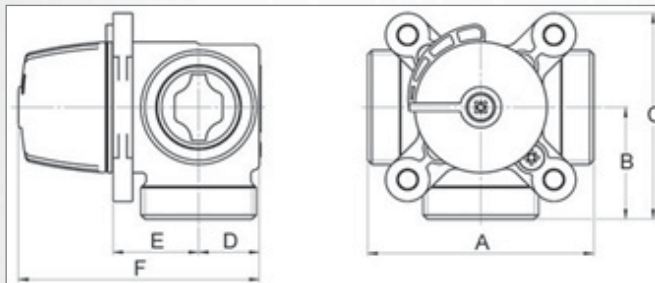

Dimensions of the new generation valves 2.0 (codes 16xxx)

CONNECTION	--	3/4" M	1" M	1" M	5/4" M	6/4" M	2" M
A	mm	80	80	80	82	84	124
B	mm	40	40	40	41	42	62
C	mm	75	68	68	76	77	98
D	mm	20	18	18	22	24	30
E	mm	28	29	29	31	32	36
F	mm	82	81	81	87	90	100
WEIGHT	kg	0.7	0.6	0.6	0.8	0.9	2.1
MAX. PRESSURE DIFFERENCE IN EITHER DIRECTION	m H ₂ O	5	5	5	5	5	5
Kvs	m³/h	2.5	4.0	6.3	12.0	15.0	24.0
CODE	--	14822	16768	16695	14826	14827	14828