

Three-way Mixing Valves with inner thread, model LK 840 2.0



Main features	
Application	heating and solar systems
Description	mixing valve with rotating inner segment
Working fluid	water, antifreeze mixture for heating and solar systems and heat pumps
Installation position	any, except for shaft (motor) downwards

Control	
Electric control	can be fitted with electric actuators with torque of 5 Nm or more
Manual control	by turning the knob
Opening angle	90° / 360°

Technical parameters	
Max. working pressure	10 bar
Max. pressure difference	5 m H ₂ O
Fluid working pressure	5 to 110 °C (120 °C in short term)
Ambient working temperat.	5 to 60 °C
Leaks	< 1 % K _{vs} at 5 m H ₂ O pressure difference

Materials	
Valve body	forged brass
Valve member and spindle	brass
Inner valve bonnet	PPS
Outer valve bonnet	aluminium
Seal	EPDM

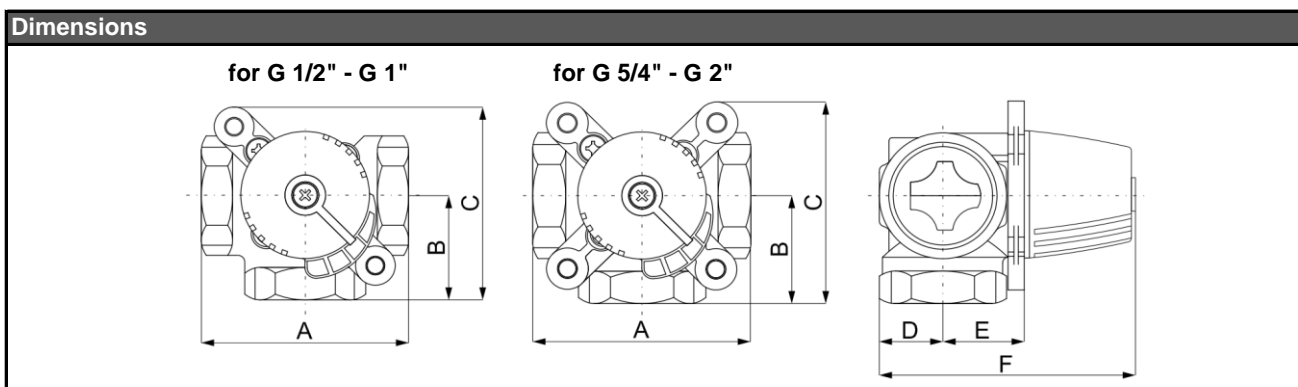

	Code	Dimensions [mm]						Weight [kg]	K _{vs} [m ³ /h]	Connection
		A	B	C	D	E	F			
LK 840 1/2F - 1,6	16764	70	35	63	18	29	81	0,5	1,6	G 1/2" F
LK 840 1/2F - 2,5	16765	70	35	63	18	29	81	0,5	2,5	G 1/2" F
LK 840 3/4F - 4	16760	70	35	63	18	29	81	0,5	4,0	G 3/4" F
LK 840 3/4F - 6,3	16698	70	35	63	18	29	81	0,5	6,3	G 3/4" F
LK 840 1F - 6,3	16758	70	35	63	18	29	81	0,5	6,3	G 1" F
LK 840 1F - 10	16700	70	35	63	18	29	83	0,5	10,0	G 1" F
LK 840 5/4F - 16	16693	84	42	77	24	32	90	0,8	16,0	G 5/4" F
LK 840 6/4F - 25	16762	106	53	88	33	43	110	1,4	25,0	G 6/4" F
LK 840 2F - 40	16697	106	53	88	33	43	110	1,6	40,0	G 2" F

Three-way Mixing Valves with inner thread, model LK 840 2.0

Pressure drop diagram

