

COOL

Refrigerated water tank



100 150 200 300 400 500 600 750 800 1000 1250 1500 2000 2500 3000 4000 5000



Refrigerated water tank.



Main features

Material	Carbon steel	
External treatment	Rustproof paint	
Internal treatment	Raw	
Maximum working pressure	6 bar	
Minimum working temperature	Refrigeration	6 °C
Maximum working temperature	Heating	95 °C
Guarantee	Tank	5 years

Accessories



Thermometer
Complete of ½" sensor sleeve



Sensor sleeve
Threaded connection ½"

Model	Use	Insulation	Nominal volume (l)	Weight (kg)
COOL 500		Armaflex 19mm + PVC	490	77
COOL 600		Armaflex 19mm + PVC	571	84
COOL 800		Armaflex 19mm + PVC	732	97
COOL 1000		Armaflex 19mm + PVC	925	114
COOL 1250		Armaflex 19mm + PVC	1284	145
COOL 1500		Armaflex 19mm + PVC	1515	162
COOL 2000		Armaflex 19mm + PVC	2054	225
COOL 2500		Armaflex 19mm + PVC	2497	252
COOL 3000		Armaflex 19mm + PVC	2959	280
COOL 4000		Armaflex 19mm + PVC	3819	431
COOL 5000		Armaflex 19mm + PVC	5055	504

COOL

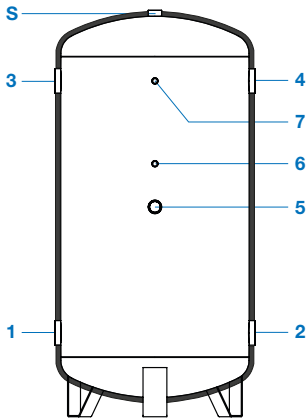

Dimension

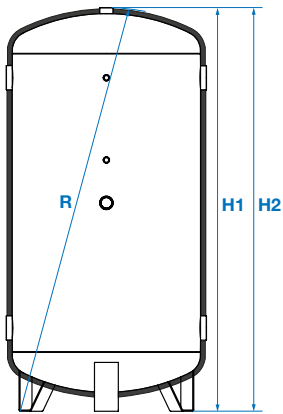

Legend			
1	Hydraulic connection	500-2000 2500-5000	3" 4"
2	Hydraulic connection	500-2000 2500-5000	3" 4"
3	Hydraulic connection	500-2000 2500-5000	3" 4"
4	Hydraulic connection	500-2000 2500-5000	3" 4"
5	Heating element		1" 1/2
6	Sensor		1/2"
7	Thermometer		1/2"
SC	Drainage		1" 1/4
S	Vent or safety valve		1" 1/2

COOL - FLANGE DN

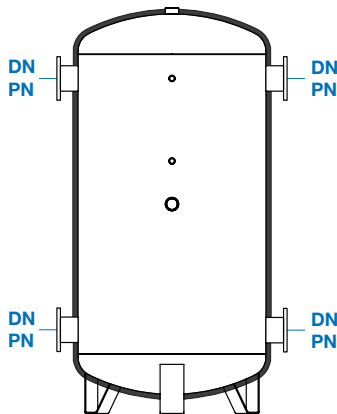

On customer request are executed special tanks with DN / PN flanges

Dimension

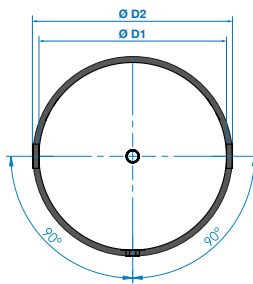

COOL 4000 - 5000

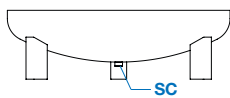

Drain fitting

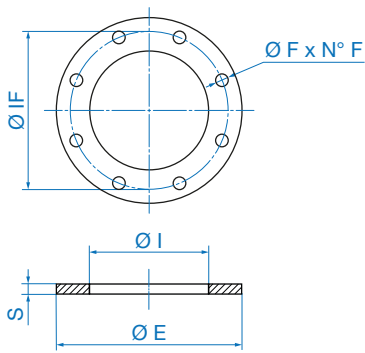

Flange DN/PN size

Flange type	Ø E (mm)	Ø I (mm)	S (mm)	IF (mm)	Ø F (mm)	N° F
DN 20 PN 6	90	27.5	14	65	11	4
DN 25 PN 6	100	34.5	14	75	11	4
DN 32 PN 6	120	43.5	16	90	14	4
DN 40 PN 6	130	49.5	16	100	14	4
DN 50 PN 6	140	61.5	16	110	14	4
DN 65 PN 6	160	77.5	16	130	14	4
DN 80 PN 6	190	90.5	18	150	18	4
DN 100 PN 6	210	116.0	18	170	18	4
DN 125 PN 6	240	141.5	20	200	18	8
DN 150 PN 6	265	170.5	20	225	18	8
DN 200 PN 6	320	221.5	22	280	18	8
DN 250 PN 6	375	276.5	24	335	18	12
DN 300 PN 6	440	327.5	24	395	22	12

Flange type	Ø E (mm)	Ø I (mm)	S (mm)	IF (mm)	Ø F (mm)	N° F
DN 20 PN 16	105	27.5	16	75	14	4
DN 25 PN 16	115	34.5	16	85	14	4
DN 32 PN 16	140	43.5	18	100	18	4
DN 40 PN 16	150	49.5	18	110	18	4
DN 50 PN 16	165	61.5	19	125	18	4
DN 65 PN 16	185	77.5	20	145	18	8
DN 80 PN 16	200	90.5	20	160	18	8
DN 100 PN 16	220	116.0	22	180	18	8
DN 125 PN 16	250	141.5	22	210	18	8
DN 150 PN 16	285	170.5	24	240	22	8
DN 200 PN 16	340	221.5	26	295	22	12
DN 250 PN 16	405	276.5	29	355	26	12
DN 300 PN 16	460	327.5	32	410	26	12

Model	1-5	3-4	5	6	7	Ø D1	Ø D2	R	H1	H2
500	325	1415	870	1045	1415	650	690	1684	1669	1669
600	350	1400	875	1055	1400	700	740	1702	1684	1684
800	350	1400	875	1055	1400	790	830	1715	1694	1694
1000	410	1710	1060	1260	1710	790	830	2081	2064	2064
1250	390	1690	1040	1240	1690	950	990	2051	2029	2029
1500	454	1754	1104	1304	1754	1000	1040	2198	2178	2178
2000	405	2005	1205	1405	2005	1100	1140	2403	2379	2379
2500	422	2022	1222	1472	2022	1200	1240	2452	2426	2426
3000	432	2232	1332	1582	2232	1250	1290	2666	2641	2641
4000	537	2337	1437	1687	2337	1400	1440	2906	2792	2792
5000	570	2370	1470	1720	2370	1600	1640	2983	2854	2854